



Vehicle History Report™

US \$44.99

2017 AUDI A4 2.0T PREMIUM

VIN: WAUGNAF42HA038218
SEDAN 4 DR
2.0L I4 F DOHC 16V
GASOLINE
FRONT WHEEL DRIVE



Branded Title: Salvage



6 Service history records



At least 1 open recall



3 Previous owners



Types of owners: Personal lease, Personal



23,978 Last reported odometer reading

CARFAX HAS THE MOST
ACCIDENT & DAMAGE
INFORMATION



This CARFAX Vehicle History Report is based only on information supplied to CARFAX and available as of 1/4/25 at 2:51:09 AM (CST). Other information about this vehicle, including problems, may not have been reported to CARFAX. Use this report as one important tool, along with a vehicle inspection and test drive, to make a better decision about your next used car.



Accident / Damage History

Not all accidents / issues are reported to CARFAX

Event 1

11/04/2019

Damage reported: minor to moderate damage

Damage Severity Scale

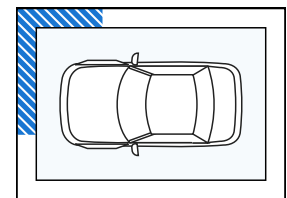

Event 2

05/28/2020

Damage reported: minor damage

Damage Severity Scale

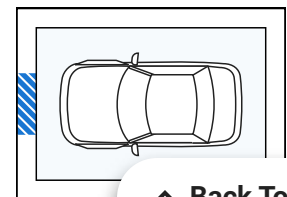
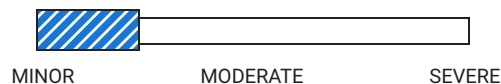

[^ Back To Top](#)

Event 3

06/19/2021

TOTAL LOSS VEHICLE

- Vehicle declared a total loss by an insurance company
- Collision damage reported

Event 4

06/28/2021

**Damage reported:
moderate to severe
damage**

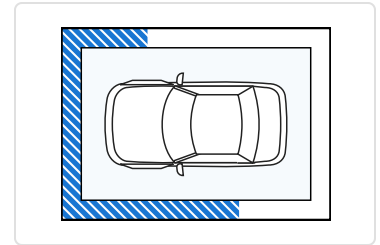
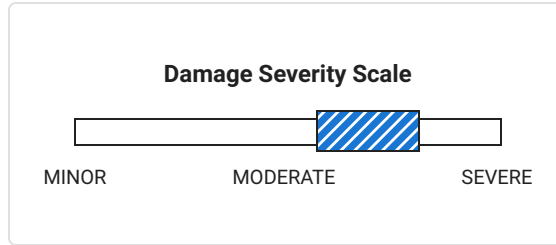

Event 5

02/07/2023

Damage reported

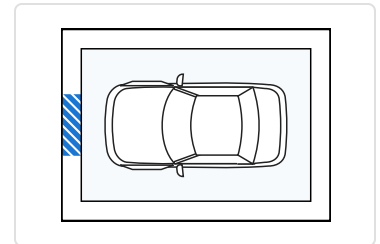

Additional History

Not all accidents / issues are reported to CARFAX

	Owner 1	Owner 2	Owner 3
Total Loss Total Loss Reported: 06/19/2021.	<input checked="" type="checkbox"/> No Issues Reported	Total Loss Reported	No New Issues Reported
Structural Damage CARFAX recommends that you have this vehicle inspected by a collision repair specialist.	<input checked="" type="checkbox"/> No Issues Reported	<input checked="" type="checkbox"/> No Issues Reported	<input checked="" type="checkbox"/> No Issues Reported
Airbag Deployment No airbag deployment reported to CARFAX.	<input checked="" type="checkbox"/> No Issues Reported	<input checked="" type="checkbox"/> No Issues Reported	<input checked="" type="checkbox"/> No Issues Reported
Odometer Check No indication of an odometer rollback.	<input checked="" type="checkbox"/> No Issues Indicated	<input checked="" type="checkbox"/> No Issues Indicated	<input checked="" type="checkbox"/> No Issues Indicated
Accident / Damage DMV title problems reported. Damage reported: 11/04/2019, 05/28/2020, 06/28/2021, and	Damage Reported	Accident Reported	Severe

02/07/2023. Accident reported: 06/19/2021.			
Manufacturer Recall At least 1 manufacturer recall requires service. Locate an authorized Audi dealer to obtain more information about this recall.	<input checked="" type="checkbox"/> No Recalls Reported	<input checked="" type="checkbox"/> No Recalls Reported	Recall Reported
Basic Warranty Original manufacturer warranty likely voided by manufacturer.	<input checked="" type="checkbox"/> Warranty Active	<input checked="" type="checkbox"/> Warranty Active	Warranty Voided

 Title History	Owner 1	Owner 2	Owner 3
Damage Brands Salvage Junk Rebuilt Fire Flood Hail Lemon	No Problem	No Problem	Alert! Problem Found
Odometer Brands Not Actual Mileage Exceeds Mechanical Limits	No Problem	No Problem	No Problem







ALERT! - Severe problems were reported by a state Department of Motor Vehicles (DMV). This vehicle does not qualify for the CARFAX Buyback Guarantee.

 Ownership History	Owner 1	Owner 2	Owner 3
The number of owners is estimated			
Year purchased	2016	2020	2021
Type of owner	Personal lease	Personal	Personal
Estimated length of ownership	3 yrs. 9 mo.	9 months	1 yr. 6 mo.
Owned in the following states/provinces	California	California	California
Estimated miles driven per year	10,525/yr	---	---
Last reported odometer reading	15,399	15,983	23,978

 Detailed History			
 Owner 1 Purchased: 2016		Personal Lease Vehicle 10,525 mi/yr	
Date	Mileage	Source	Comments
Not Reported		NICB	Vehicle manufactured at original dealer

[^ Back To Top](#)

09/07/2016	13	Audi San Diego San Diego, CA 858-578-8600 audisandiego.com ★ 4.4 / 5.0 243 Verified Reviews ♥ 247 Customer Favorites	Vehicle offered for sale
09/09/2016		Audi San Diego San Diego, CA 858-578-8600 audisandiego.com ★ 4.4 / 5.0 243 Verified Reviews ♥ 247 Customer Favorites	 Vehicle serviced - Pre-delivery inspection completed - Vehicle washed/detailed
12/27/2016	64	California Motor Vehicle Dept. San Diego, CA	Odometer reading reported
01/07/2017	816	Audi San Diego San Diego, CA 858-578-8600 audisandiego.com ★ 4.4 / 5.0 243 Verified Reviews ♥ 247 Customer Favorites	 Vehicle serviced - Maintenance inspection completed - Tire condition and pressure checked
01/09/2017		California Motor Vehicle Dept. San Diego, CA	Title issued or updated - First owner reported - Loan or lien reported
01/10/2017		Service Facility	 Vehicle reconditioned
01/13/2017		California Motor Vehicle Dept. San Diego, CA	Title issued or updated - Titled or registered as personal lease vehicle - Loan or lien reported
06/14/2017	5,388	Audi San Diego San Diego, CA 858-578-8600 audisandiego.com ★ 4.4 / 5.0 243 Verified Reviews ♥ 247 Customer Favorites	 Vehicle serviced - Maintenance inspection completed - 10,000 mile service performed - Tire condition and pressure checked
09/27/2017	10,097	Audi San Diego San Diego, CA 858-578-8600 audisandiego.com	 Vehicle serviced - Maintenance inspection completed - Tire condition and pressure checked

[^ Back To Top](#)

★ 4.4 / 5.0

243 Verified Reviews

♥ 247 Customer Favorites

06/27/2018 15,399

Audi San Diego
San Diego, CA
858-578-8600
audisandiego.com



Vehicle serviced

- Maintenance inspection completed
- Oil and filter changed
- Tire condition and pressure checked

★ 4.4 / 5.0

243 Verified Reviews

♥ 247 Customer Favorites

11/04/2019

Damage Report



Damage reported: minor to moderate damage

- Damage to front
- Damage to right front



CARFAX HAS THE MOST ACCIDENT & DAMAGE INFORMATION

Damage Severity Scale



Damage Location

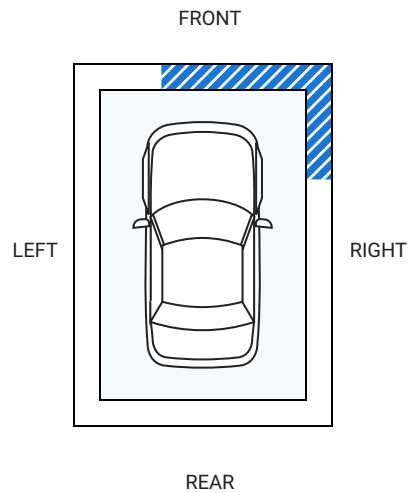

05/28/2020

Damage Report



Damage reported: minor damage

- Damage to front

Damage Severity Scale

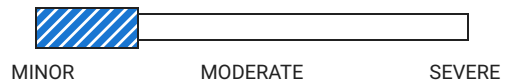

Damage Location

FRONT

[^ Back To Top](#)

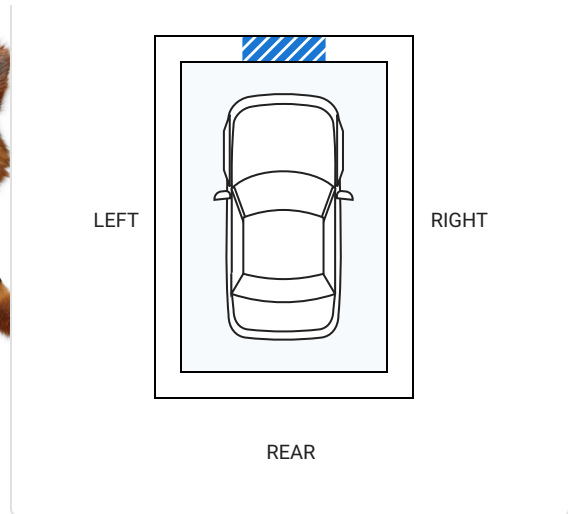



CARFAX HAS THE MOST ACCIDENT & DAMAGE INFORMATION



Owner 2
Purchased: 2020

Personal Vehicle

Date	Mileage	Source	Comments
10/01/2020	15,983	California Motor Vehicle Dept. Studio City, CA	Title issued or updated - New owner reported
06/19/2021		Damage Report	 TOTAL LOSS VEHICLE - Vehicle declared a total loss by an insurance company - Collision damage reported
			There are many reasons an insurance company will declare a vehicle a total loss. Have this vehicle inspected by a qualified technician before you buy. Learn More
06/28/2021		Damage Report	 Damage reported: moderate to severe damage - Damage to front - Damage to left front - Damage to right front - Damage to left side

Damage Severity Scale

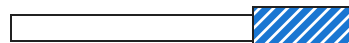

[^ Back To Top](#)



CARFAX HAS THE MOST ACCIDENT & DAMAGE INFORMATION

MINOR MODERATE SEVERE

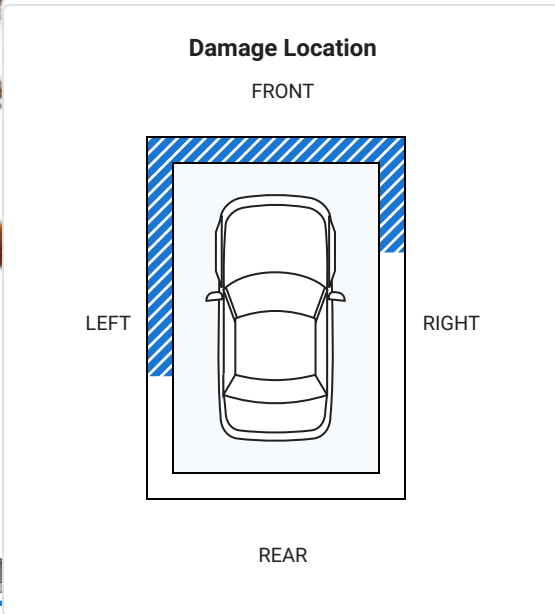

Owner 3
Purchased: 2021

Personal Vehicle

Date	Mileage	Source	Comments
07/16/2021	23,978	California Motor Vehicle Dept. Sacramento, CA	Odometer reading reported
07/23/2021		California Motor Vehicle Dept. Sacramento, CA	 New owner reported - SALVAGE TITLE/CERTIFICATE ISSUED
11/23/2021		Audi	Manufacturer Compliance Recall issued - NHTSA #21V874 - Recall #74E3 PASSENGER OCCUPANT DETECTION SYSTEM (PODS) - Status: Remedy Available Locate an authorized Audi dealer to obtain more information about this recall <input type="button" value="⊖ Learn more about this recall"/>

Description: The affected vehicles are equipped with a passenger occupant detection system (also known as Body Sense) in the front passenger seat. On these vehicles, the system is integrated in the seat heating and controls the activation of the front passenger airbag. The seat heating is connected to the Body Sense control unit under the front passenger seat via a wire. If the wire has a contact fault, it may cause the passenger

[^ Back To Top](#)

occupant detection system (PODS) to detect a malfunction and switch off the passenger airbag even though the seat may be occupied. As designed, a warning light in the instrument panel comes on together with an acoustic warning sound and an error message is displayed in the instrument cluster. The airbag indicator light shows "passenger airbag off". In the event of a crash, there would be an increased risk of injury to the occupant seated in the front passenger seat if the passenger airbag is switched off/not working.

Remedy: Depending on the seat type, the seat heating mats including the connecting cable or the entire seat cover including the connecting cable will be replaced.

02/07/2023

Damage Report



Damage reported

- Damage to front

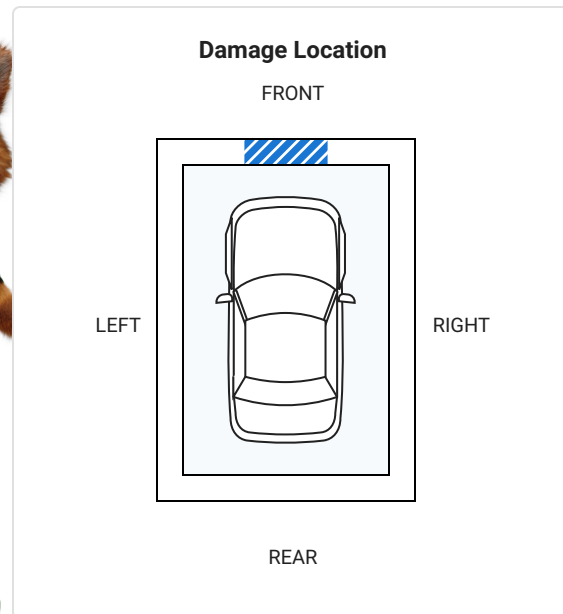

**CARFAX HAS THE MOST
ACCIDENT & DAMAGE
INFORMATION**

03/03/2023

Vehicle Exporter

Vehicle exported from

- Los Angeles, CA and imported to
- Klaipeda, Lithuania

Have Questions? Consumers, please visit our Help Center at www.carfax.com. Dealers or Subscribers, please visit our Help Center at www.carfaxonline.com.



Glossary

Accident Indicator

CARFAX receives information about accidents in all 50 states, the District of Columbia and Canada.

Not every accident is reported to CARFAX. As details about the accident become available, those additional details are added to the CARFAX Vehicle History Report. CARFAX recommends that you have this vehicle inspected by a qualified mechanic.

- According to the National Safety Council, Injury Facts, 2021 edition, 5% of the 276 million registered vehicles in the U.S. were involved in an accident in 2019. Over 77% of these were considered

[^ Back To Top](#)

moderate.

- This CARFAX Vehicle History Report is based only on information supplied to CARFAX and available as of 1/4/25 at 2:51:09 AM (CST). Other information about this vehicle, including problems, may not have been reported to CARFAX. Use this report as one important tool, along with a vehicle inspection and test drive, to make a better decision about your next used car.

Damage Indicator

Damage can be a result of many different types of events. Examples include contact with objects (other cars, trees, traffic signs, road debris, etc), vandalism, or weather-related events. Not every damage event is reported to CARFAX. As details about the damage event become available, those additional details are added to the CARFAX Vehicle History Report. CARFAX recommends that you have this vehicle inspected by a qualified mechanic.

- This CARFAX Vehicle History Report is based only on information supplied to CARFAX and available as of 1/4/25 at 2:51:09 AM (CST). Other information about this vehicle, including problems, may not have been reported to CARFAX. Use this report as one important tool, along with a vehicle inspection and test drive, to make a better decision about your next used car.

Damage Severity

Damage events result in one of the following severity levels:

- Minor: Generally, minor damage is cosmetic (including dents or scratches), may only require reconditioning, and typically does not compromise a vehicle's operation and/or safety.
- Moderate: Moderate damage may affect multiple components of the vehicle and may impair the vehicle's operation and/or safety.
- Severe: Severe damage usually affects multiple components of the vehicle and is likely to compromise the vehicle's operation and/or safety.

CARFAX recommends getting a pre-purchase inspection at a certified collision repair facility.

First Owner

When the first owner(s) obtains a title from a Department of Motor Vehicles as proof of ownership.

Manufacturer Recall

Automobile manufacturers issue recall notices to inform vehicle owners of a safety defect or failure to meet minimum federal safety or emissions standards. Manufacturer recalls are repaired at no cost to the customer.

New Owner Reported

When a vehicle is sold to a new owner, the Title must be transferred to the new owner(s) at a Department of Motor Vehicles.

Ownership History

CARFAX defines an owner as an individual or business that possesses and uses a vehicle. Not all title transactions represent changes in ownership. To provide estimated number of owners, CARFAX proprietary technology analyzes all the events in a vehicle history. Estimated ownership is available for vehicles manufactured after 1991 and titled solely in the US including Puerto Rico. Dealers sometimes opt to take ownership of a vehicle and are required to in the following states: Maine, Massachusetts, New Jersey, Ohio, Oklahoma, Pennsylvania and South Dakota. Please consider this as you review a vehicle's estimated ownership history.

Salvage Title

A Salvage Title is issued on a vehicle damaged to the extent that the cost of repairing the vehicle exceeds approximately 75% of its pre-damage value. This damage threshold may vary by state. Some states treat Junk titles the same as Salvage but the majority use this title to indicate that a vehicle is not road worthy and cannot be titled again in that state. The following eleven states also use Salvage titles to identify stolen vehicles - AZ, FL, GA, IL, MD, MN, NJ, NM, NY, OK and OR.

Title Issued

A state issues a title to provide a vehicle owner with proof of ownership. Each title has a unique number. Each title or registration record on a CARFAX report does not necessarily indicate a change in ownership. In Canada, a registration and bill of sale are used as proof of ownership.

Total Loss Vehicle

An insurance or fleet company declares a vehicle a total loss when a claim exceeds approximately 75% of its pre-damage value or if the vehicle is stolen and not recovered. This damage threshold varies by company. These companies typically take possession and obtain the title. Not all total loss vehicles result in a DMV-reported branded title. This may occur when an insurance company's definition of a total loss is different than the s

[^ Back To Top](#)

definition for a branded title or when the owner of the vehicle is a self-insured company, like a fleet or rental company.

Follow Us:



facebook.com/CARFAX



[@CARFAXinc](https://twitter.com/CARFAXinc)



About CARFAX

CARFAX DEPENDS ON ITS SOURCES FOR THE ACCURACY AND RELIABILITY OF ITS INFORMATION. THEREFORE, NO RESPONSIBILITY IS ASSUMED BY CARFAX OR ITS AGENTS FOR ERRORS OR OMISSIONS IN THIS REPORT. CARFAX FURTHER EXPRESSLY DISCLAIMS ALL WARRANTIES, EXPRESS OR IMPLIED, INCLUDING ANY IMPLIED WARRANTIES OF MERCHANTABILITY OR FITNESS FOR A PARTICULAR PURPOSE.

© 2025 CARFAX, Inc., part of S&P Global. All rights reserved.
1/4/25 2:51:09 AM (CST)

I have reviewed and received a copy of the CARFAX Vehicle History Report for this 2017 AUDI A4 vehicle (VIN: WAUGNAF42HA038218), which is based on information supplied to CARFAX and available as of 1/4/25 at 3:51 AM (EST).

Customer Signature

Date

Dealer Signature

Date

[^ Back To Top](#)

